

Instruction for Use

021075/03/14

Wind Transmitter compact

4.3519.xx.140 ... 961



ADOLF THIES GmbH & Co. KG

Hauptstraße 76 37083 Göttingen Germany
Box 3536 + 3541 37025 Göttingen
Phone +49 551 79001-0 Fax +49 551 79001-65
www.thiesclima.com info@thiesclima.com

Safety Instructions

- Before operating with or at the device/product, read through the operating instructions. This manual contains instructions which should be followed on mounting, start-up, and operation. A non-observance might cause:
 - failure of important functions
 - endangerment of persons by electrical or mechanical effect
 - damage to objects
- Mounting, electrical connection and wiring of the device/product must be carried out only by a qualified technician who is familiar with and observes the engineering regulations, provisions and standards applicable in each case.
- Repairs and maintenance may only be carried out by trained staff or **Adolf Thies GmbH & Co. KG**. Only components and spare parts supplied and/or recommended by **Adolf Thies GmbH & Co. KG** should be used for repairs.
- Electrical devices/products must be mounted and wired only in a voltage-free state.
- **Adolf Thies GmbH & Co KG** guarantees proper functioning of the device/products provided that no modifications have been made to the mechanics, electronics or software, and that the following points are observed:
- All information, warnings and instructions for use included in these operating instructions must be taken into account and observed as this is essential to ensure trouble-free operation and a safe condition of the measuring system / device / product.
- The device / product is designed for a specific application as described in these operating instructions.
- The device / product should be operated with the accessories and consumables supplied and/or recommended by **Adolf Thies GmbH & Co KG** .
- Recommendation: As it is possible that each measuring system / device / product may, under certain conditions, and in rare cases, may also output erroneous measuring values, it is recommended using redundant systems with plausibility checks for **security-relevant applications**.

Environment

- As a longstanding manufacturer of sensors Adolf Thies GmbH & Co KG is committed to the objectives of environmental protection and is therefore willing to take back all supplied products governed by the provisions of "ElektroG" (German Electrical and Electronic Equipment Act) and to perform environmentally compatible disposal and recycling. We are prepared to take back all Thies products concerned free of charge if returned to Thies by our customers carriage-paid.
- Make sure you retain packaging for storage or transport of products. Should packaging however no longer be required, please arrange for recycling as the packaging materials are designed to be recycled.



Documentation

- © Copyright **Adolf Thies GmbH & Co KG**, Göttingen / Germany
- Although these operating instruction has been drawn up with due care, **Adolf Thies GmbH & Co KG** can accept no liability whatsoever for any technical and typographical errors or omissions in this document that might remain.
- We can accept no liability whatsoever for any losses arising from the information contained in this document.
- Subject to modification in terms of content.
- The device / product should not be passed on without the/these operating instructions.

Contents

1	Models	4
2	Application	5
3	Mode of Operation	5
4	Recommendation Site Selection / Standard Installation	5
5	Installation.....	6
5.1	Mechanical Mounting.....	6
5.2	Electrical Mounting	7
5.3	Plug mounting	7
6	Connecting Diagram	8
7	Maintenance	9
8	Technical Data	10
9	Dimension diagram	11
10	Accessories	12
11	EC-Declaration of Conformity	13

Figure

Figure 1:	plug mounting.....	7
Figure 2:	Connecting Diagram for Models with fixed Connecting Cable	8
Figure 3:	Connecting Diagram for Models with Connector.....	9
Figure 4:	Dimensional Drawing Model cable gland	11
Figure 5:	Dimensional Drawing Model plug	11
Figure 6:	Counter nut	12

1 Models

Order - No.	Electrical Output	Measuring range	Heating power	Connection
4.3519.00.140 4.3519.00.840*	0...20 mA	0...50 m/s	20 W	12 m Cable LiYCY 6 x 0,25 mm ²
4.3519.00.141	4...20 mA	0...50 m/s	20 W	12 m Cable LiYCY 6 x 0,25 mm ²
4.3519.00.161	0...10 V	0...50 m/s	20 W	12 m Cable LiYCY 6 x 0,25 mm ²
4.3519.00.167	0...2 V	0...50 m/s	20 W	12 m Cable LiYCY 6 x 0,25 mm ²
4.3519.00.173	0...5 V	0...50 m/s	20 W	12 m Cable LiYCY 6 x 0,25 mm ²
4.3519.00.361	0...10 V	0...3 m/s max. 13,8 V @ >3m/s	20 W	12 m Cable LiYCY 6 x 0,25 mm ²
4.3519.00.441	4...20 mA	0...40 m/s	20 W	3 m PUR -Cable 6 x 0,25 mm ²
4.3519.00.641	4...20 mA	0...60 m/s	20 W	12 m Cable LiYCY 6 x 0,25 mm ²
4.3519.00.740	0...20 mA	0...50 m/s	20 W	7 pol. Plug
4.3519.00.741	4...20 mA	0...50 m/s	20 W	7 pol. Plug
4.3519.00.761	0...10 V	0...50 m/s	20 W	7 pol. Plug
4.3519.00.773	0...5 V	0...50 m/s	20 W	7 pol. Plug
4.3519.00.961	0...10 V	0...15 m/s	20 W	12 m Cable LiYCY 6 x 0,25 mm ²
4.3519.01.140	0...20 mA	0...50 m/s	20 W	1,5 -3 m Spiral Cable LiYY 6x0,14 mm ²
4.3519.02.141	4...20 mA	0...50 m/s	10 W	2 m Cable 6 x 0,56 mm ²
4.3519.04.441	4...20 mA	0...40 m/s	20 W	0,95 m PUR- Cable 6 x 0,25 mm ²
4.3519.05.141	4...20 mA	0...50 m/s	20 W	15 m Cable LiYCY 6 x 0,25 mm ²
4.3519.05.161	0...10 V	0...50 m/s	20 W	15 m Cable LiYCY 6 x 0,25 mm ²
4.3519.05.641	4...20 mA	0...60 m/s	20 W	15 m Cable LiYCY 6 x 0,25 mm ²
4.3519.10.441	4...20 mA	0...40 m/s	Without heating	12 m Cable LiYCY 6 x 0,25 mm ²
4.3519.20.141	4...20 mA	0...50 m/s	10 W	12 m Cable LiYCY 6 x 0,25 mm ²
4.3519.39.141	4...20 mA	0...50 m/s	20 W	12 m Cable LiYCY 6 x 0,25 mm ² with cable lug at the shield
4.3519.40.140	0...20 mA	0...50 m/s	60 W	12 m Cable LiYCY 6 x 0,5 mm ²
4.3519.40.141	4...20 mA	0...50 m/s	60 W	12 m Cable LiYCY 6 x 0,5 mm ²
4.3519.40.161	0...10 V	0...50 m/s	60 W	12 m Cable LiYCY 6 x 0,5 mm ²
4.3519.40.167	0...2 V	0...50 m/s	60 W	12 m Cable LiYCY 6 x 0,5 mm ²
4.3519.40.173	0...5 V	0...50 m/s	60 W	12 m Cable LiYCY 6 x 0,5 mm ²
4.3519.40.740	0...20 mA	0...50 m/s	60 W	7 pol. Plug
4.3519.40.741	4...20 mA	0...50 m/s	60 W	7 pol. Plug
4.3519.40.761	0...10 V	0...50 m/s	60 W	7 pol. Plug

* Counter nut inverse-mounted, see figure 6.

2 Application

The wind transmitter detects the horizontal wind speed. The measured values are available at the output as analogue voltage or current signal to control for instance wind power plant.

An electronically-regulated heating system has been installed in some models (see chapter 1) for winter time use, in order to prevent the ball-bearing and the external rotation parts from freezing.

Thanks to the 60-Watt-heating as well as to the optimized regulating characteristic, model no. 4.3519.40.xxx is especially suited for the extremely difficult application in high mountains or at other critical sites, where icing is to be expected.

3 Mode of Operation

The cup star (in ball bearing) is set into rotation by the wind. An opto-electronic speed scanning produces a frequency which is transformed into an analogue signal by an integrated measuring transformer.

The outer parts of the instrument are made of corrosion-resistant materials. Labyrinth gaskets protect the parts inside the instrument against precipitations.

4 Recommendation Site Selection / Standard Installation

In general wind measurement instruments should be able to detect the wind conditions of a large area. In order to obtain comparable values when determining the surface wind, measurements should be taken at a height of 10 meters over an even area with no obstacles. An area with no obstacles means that the distance between the wind direction transmitter and an obstacle should be at least 10 times the height of the obstacle (s. VDI 3786). If it is not possible to fulfil this condition then the wind direction transmitter should be set up a height where local obstacles do not influence the measured values to any significant extent (approx. 6-10 m above the obstacle). The wind direction transmitter should be set up in the centre of flat roofs and not on the edge in order to avoid any preferential directions.

5 Installation

Attention:

Storing, mounting and operation under weather conditions is permissible only in vertical position, as otherwise water can get into the instrument.

Remark:

When using fastening adapters (angle, traverses, etc.) please take a possible effect by turbulences into consideration.

Caution:

The device may only be supplied with a power supply of the „Class 2, limited power“.

5.1 Mechanical Mounting

The mounting of the transmitter could be done for example at a support with a boring of PG 21 or on hangers with a boring of 29 mm Ø.

Tools:

Hexagonal wrench SW36

Procedure:

1. Push cable/ plug connector of the wind transmitter through the borehole of the mast, tube, arm etc.
2. Put wind transmitter on mast, tube, arm etc.
3. Safeguard the wind direction transmitter by two hexagonal nuts (PG21, SW 36).

Caution: The Hexagon nuts must be tightened to 6 Nm.

Remark:

The support is not included in delivery.

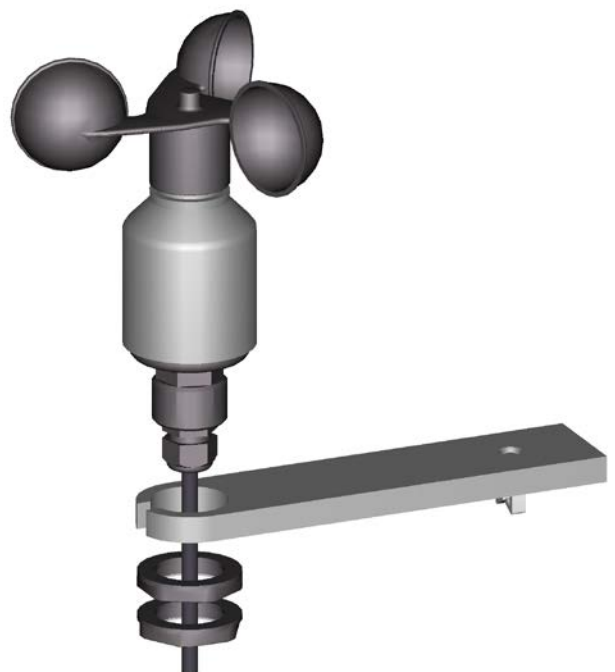

5.2 Electrical Mounting

For electrical connection please refer to the connecting diagram.

5.3 Plug mounting

Applies only to instruments with connection „plug“.

Coupling socket, Typ:Binder, Serial 423, EMC with cable clamp

Cable connection: without cable shield

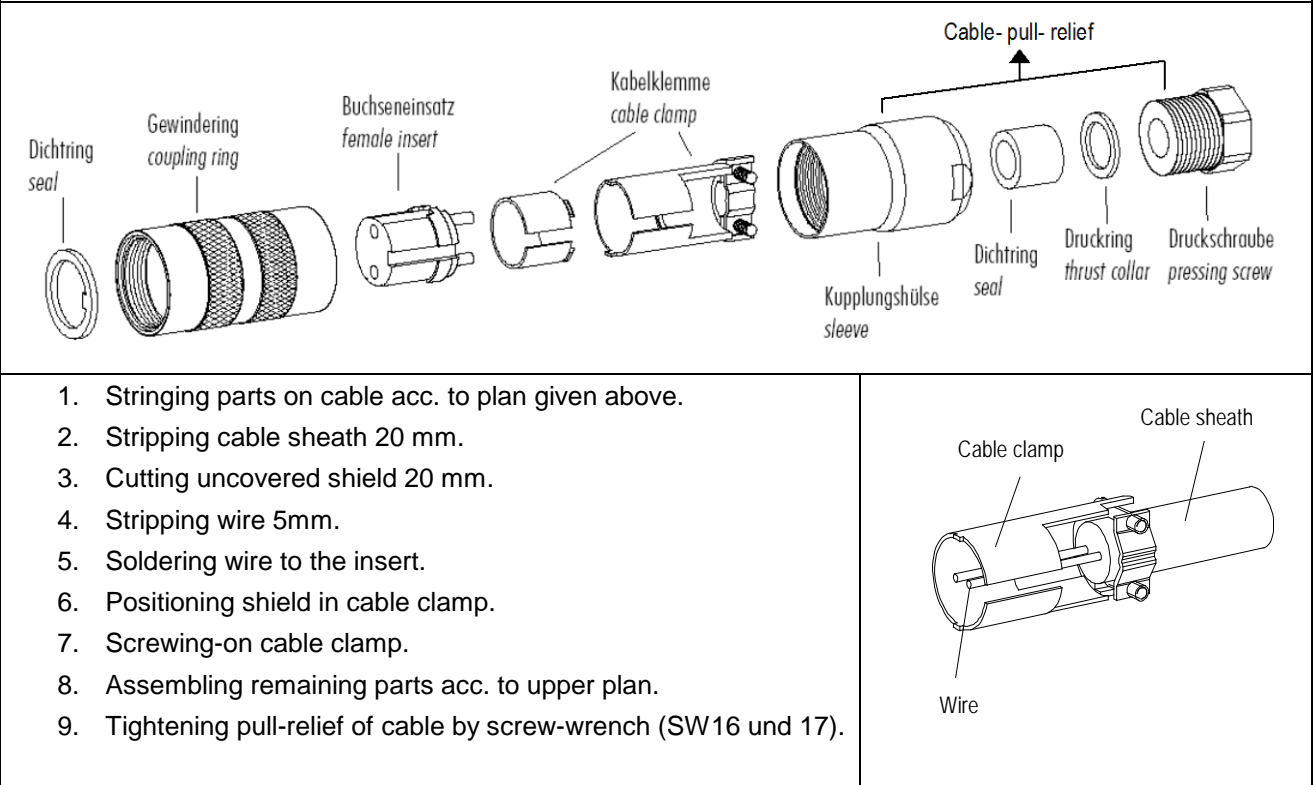

Figure 1: plug mounting

6 Connecting Diagram

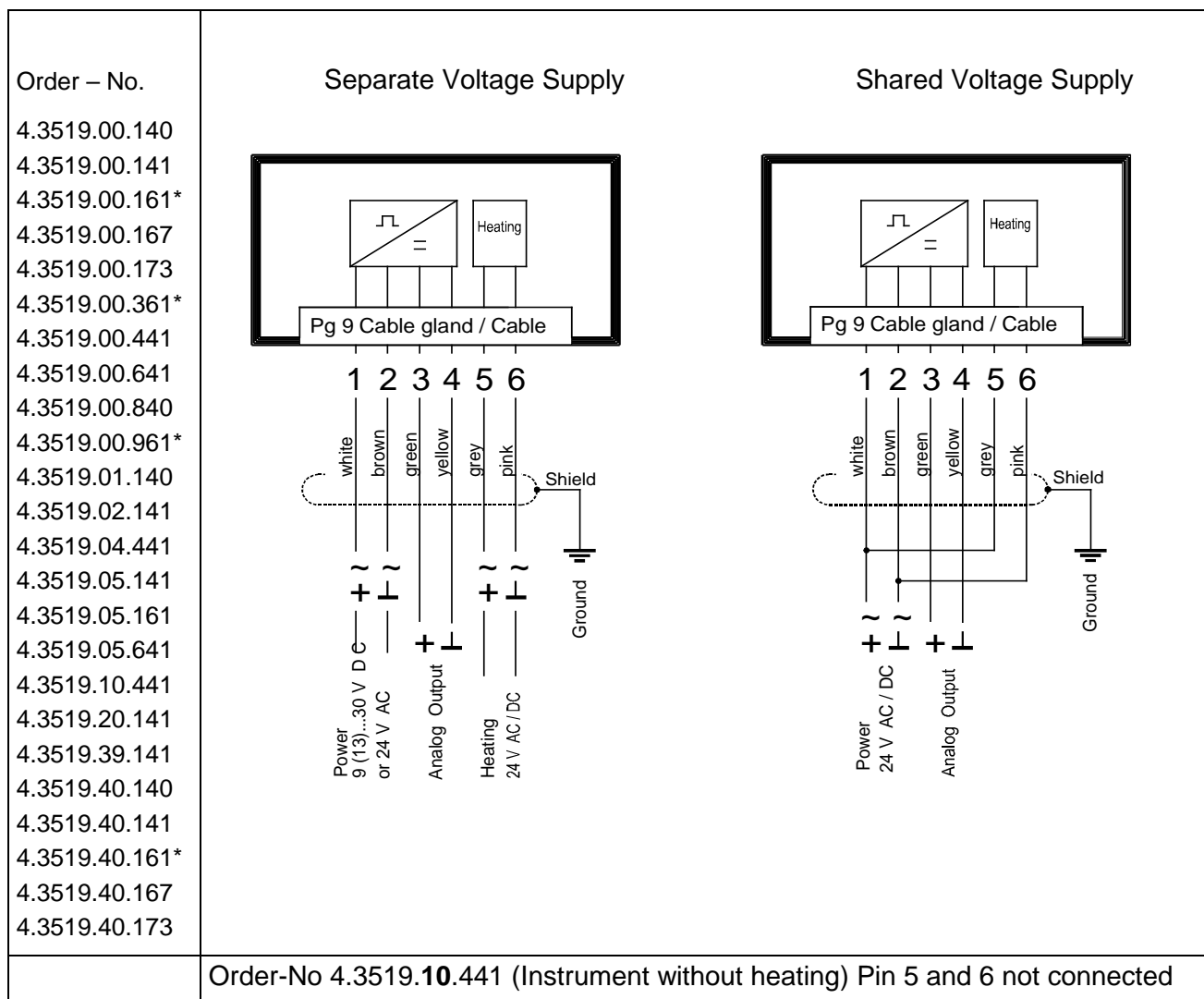

Figure 2: Connecting Diagram for Models with fixed Connecting Cable

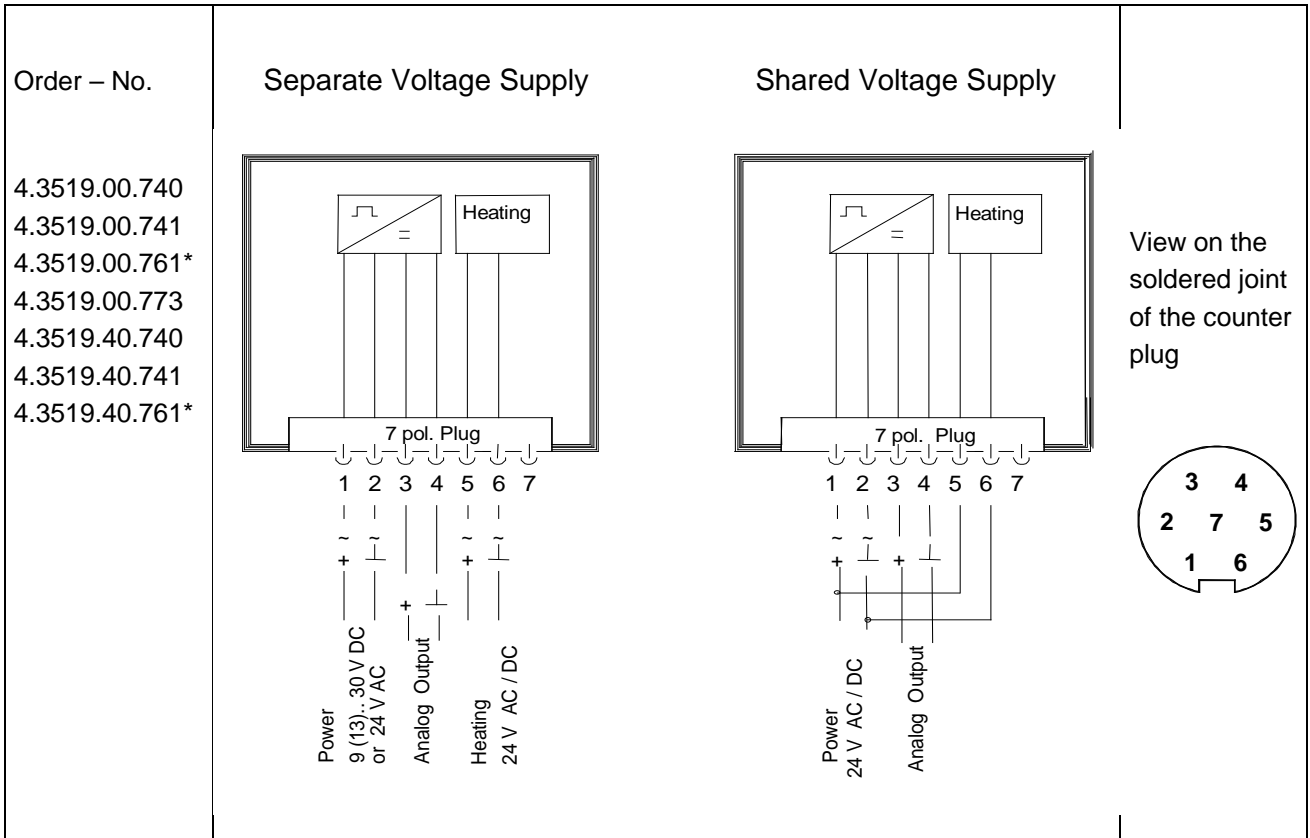

Figure 3: Connecting Diagram for Models with Connector

7 Maintenance

After proper mounting the instrument works maintenance free.

Heavy pollution can clog up the slit between the rotating and the stationary parts of the wind transmitter. This slit must be kept clean.

Cleaning

For the cleaning of the device should use a damp cloth without chemical cleaning agents are used.

8 Technical Data

Measuring range	See model
Resolution	0,1 m/s
Starting velocity	0,5 m/s
Accuracy	± 0,5 m/s or ± 3% of measuring value
Delay distance	< 3,5 m (acc. to DIN ISO 17713-1)
Measuring principle	Opto-electronic (slotted disc)
Electrical output	See model
Load for current output (mA) for current output (V)	max. 500 Ohm (for operating voltage > 15 V DC) min. 1 kΩ
Electrical supply for electronics	
	U: 9...30 V DC oder 24 V AC/DC I: 0,05A P: 1,5 W
*für 0 -10 V output	U: 13...30 V DC oder 24 V AC/DC I: 0,05A P: 1,5 W
Electrical supply for heating	
4.3519.00/01/02/04/05/20/39.xxx	U: 24V AC/DC, 45...65Hz I: 0,83A P: 20 W
4.3519.20.xxx	U: 24V AC/DC, 45...65Hz I: 0,42A P: 10 W
4.3519.40.xx	U: 24V AC/DC, 45...65Hz I: 2,5A P: 60 W
Operating voltage heating	-40°C...70°C
Survival speed	maximally 80 m /s, 30 minutes
Connection	See model
Dimensions	See dimensional drawing
Montage	For ex. onto mast tube with receptacle thread Pg 21 or boring Ø 29 mm
Protection	IP 55
Weight	0,40 – 0,75 kg depending on model
Material	
Housing	Aluminium (AlMgSi1)
Cup star	Synthetic, with fibre glass (PC-GF10)
Bottom	Synthetic (POM H2320)

9 Dimension diagram

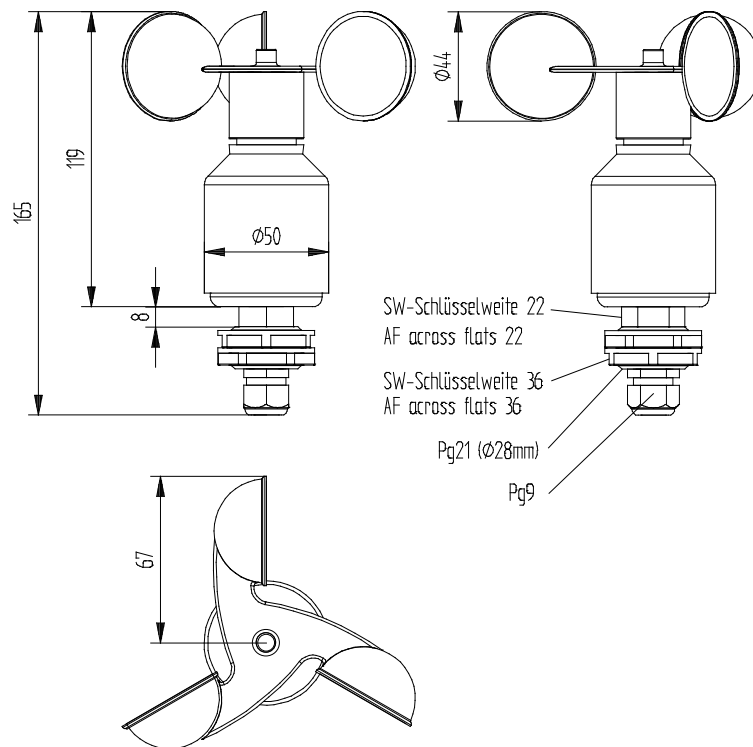

Figure 4: Dimensional Drawing Model cable gland

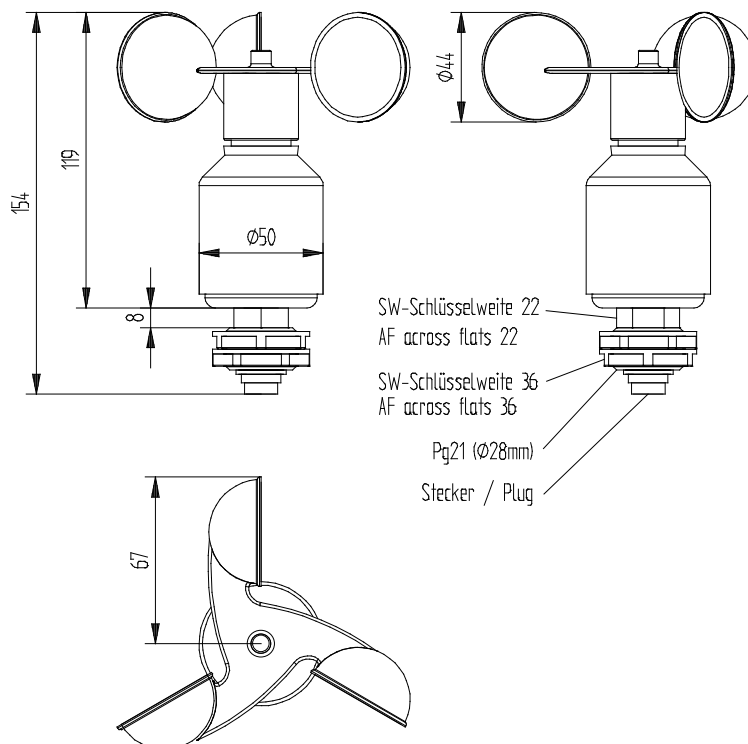

Figure 5: Dimensional Drawing Model plug

	4.3129.xx.xxx	4.3129.00.840
Assembly condition of the counter nut ex works		

Figure 6: Counter nut

10 Accessories

For the wind transmitter the following accessories are available:

Traverse	4.3171.30.000	Clamping range: Ø 48 ... 102 mm
For mounting the wind transmitter and wind direction transmitter <i>compact</i> jointly onto a mast.	4.3171.31.000	Clamping range: Ø 116 ... 200 mm Sensor distance: 0,8 m Material: Aluminium
Traverse, short	4.3171.40.000	Clamping range: Ø 48 ... 102 mm
For mounting the wind transmitter <i>compact</i> onto a mast.	4.3171.41.000	Clamping range: Ø 116 ... 200 mm Length: 0,4 m Material: Aluminium
Lightning Rod	506351	Length: 0,56 m
For mounting onto the a/m traverse.		Material: stainless steel

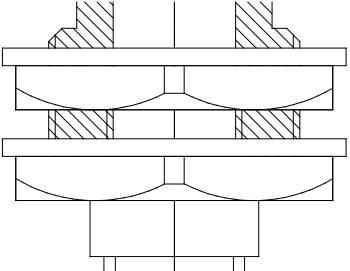
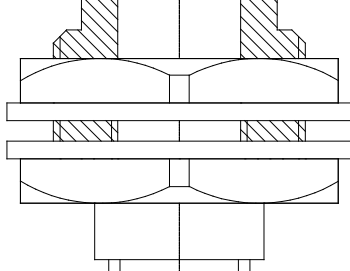
Other accessories such as cables, power supply units, masts as well as additional mast- or system-constructions on request.

11 EC-Declaration of Conformity

Document-No.: 001221

Month: 03 Year: 14

Manufacturer: **ADOLF THIES GmbH & Co. KG**

Hauptstr. 76
D-37083 Göttingen
Tel.: (0551) 79001-0
Fax: (0551) 79001-65
email: Info@ThiesClima.com

Description of Product: **Wind Transmitter – compact analog**

Article No.	4.3519.00.140	4.3519.00.141	4.3519.00.161	4.3519.00.167
4.3519.00.173	4.3519.00.361	4.3519.00.441	4.3519.00.541	4.3519.00.641
4.3519.00.740	4.3519.00.741	4.3519.00.761	4.3519.00.773	4.3519.00.840
4.3519.00.961	4.3519.01.140	4.3519.02.141	4.3519.02.441	4.3519.03.141
4.3519.04.441	4.3519.05.141	4.3519.05.161	4.3519.05.641	4.3519.06.441
4.3519.09.141	4.3519.10.441	4.3519.20.141	4.3519.39.141	4.3519.40.140
4.3519.40.141	4.3519.40.161	4.3519.40.167	4.3519.40.173	4.3519.40.740
4.3519.40.741	4.3519.40.761	4.3519.53.141	4.3519.54.141	4.3519.83.141
4.3519.90.741				

specified technical data in the document: **021072/03/14; 021190/12/10; 021455/06/07; 021533/02/08
021709/08/12; 021734/07/13**

The indicated products correspond to the essential requirement of the following European Directives and Regulations:

2004/108/EC	DIRECTIVE 2004/108/EC OF THE EUROPEAN PARLIAMENT AND OF THE COUNCIL of 15 December 2004 on the approximation of the laws of the Member States relating to electromagnetic compatibility and repealing Directive 89/336/EEC
2006/95/EC	DIRECTIVE 2006/95/EC OF THE EUROPEAN PARLIAMENT AND OF THE COUNCIL of 12 December 2006 on the harmonisation of the laws of Member States relating to electrical equipment designed for use within certain voltage limits
552/2004/EC	Regulation (EC) No 552/2004 of the European Parliament and the Council of 10 March 2004 on the interoperability of the European Air Traffic Management network (the interoperability Regulation)

The indicated products comply with the regulations of the directives. This is proved by the compliance with the following standards:

Reference number	Specification
IEC 61000-6-2: 2005	Electromagnetic compatibility Immunity for industrial environment
IEC 61000-6-3: 2006	Electromagnetic compatibility Emission standard for residential, commercial and light industrial environments
IEC 61010-1: 2010	Safety requirements for electrical equipment for measurement, control, and laboratory use. Part 1: General requirements

Place: Göttingen

Date: 14.03.2014

Legally binding signature:

issuer:

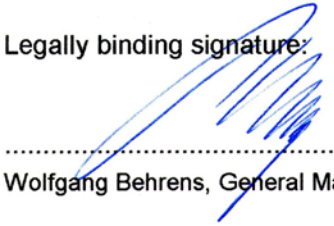
.....
Wolfgang Behrens, General Manager

.....
Joachim Beinhorn, Development Manager

This declaration certifies the compliance with the mentioned directives, however does not include any warranty of characteristics.
Please pay attention to the security advises of the provided instructions for use.



ADOLF THIES GmbH & Co. KG

Hauptstraße 76 37083 Göttingen Germany
P.O. Box 3536 + 3541 37025 Göttingen
Phone +49 551 79001-0 Fax +49 551 79001-65
www.thiesclima.com info@thiesclima.com



- Alterations reserved-